

ORGAN NEEDLES



A SEWING MACHINE IS ONLY AS GOOD AS THE NEEDLE IN IT!

The Organ Needle Company works closely with all of Japan's sewing machine builders to design and manufacture needles for optimal performance. A machine builder cannot afford to buy an inferior needle at any price!

Next time you order replacement needles for your best machines, order the needles your machine builder uses. When you buy **ORGAN** needles for their outstanding performance you get their *low price* as a bonus.

Would any machine builder jeopardize his reputation by supplying an inferior needle with his machine? How much could he save, .10 or .20 per needle, \$1.00 or \$2.00 per machine? The price of a needle is not a factor to him -- *PERFORMANCE is the factor!* Price is an added benefit, a bonus you always get with every box of **ORGAN** needles.

**ORGAN needles are supplied with every new machine from:
BROTHER, JUKI, MITSUBISHI, YAMATO, KANSAI, PEGASUS, CONSEW,
TAJIMA, BARUDAN, NAKAJIMA, KINGLINE, NEWLONG, TOYOTA,
RENOWN, and many more...**

After you've used-up the *free* needles packed with your new machine, which performed flawlessly, WHY change to a more expensive needle? What can you gain? How could any needle at any price be better than those made to the machine builder's specifications? How could a copy, even a more expensive copy, be better than O.E.M. specs?

Diamond Needle Corp

60 Commerce Rd. Carlstadt, NJ 07072
Phone: (201)507-1771 . (800)221-5818
FAX:(201)507-1715 (800)833-3363 E-mail:info@diamondneedle.com



MARCH 1, 2004

PRICES SUBJECT TO CHANGE WITHOUT NOTICE. NOT RESPONSIBLE FOR TYPOGRAPHICAL ERRORS.

GUIDE TO SELECTING THE RIGHT NEEDLE

The Organ Needle Company works closely with some of the leading machine makers such as Tajima and Barudan. In this way, they have matched their expertise as the world's largest needle maker, and the particular needs of each machine builder. Realizing a machine is only as good as the needle in it, each machine maker wants to be sure to have the right needle design to enhance the performance of their machine.

We carry the largest variety of needles for embroidery machines. While no one can prescribe a specific needle for any situation, we hope to explain the features of those we carry. With reasonable knowledge of the available needles, any operator can make educated decisions to deal with any embroidery task.

16x257: This is the standard sewing machine needle that other needle makers offer for Tajima and similar embroidery machines. It was originally designed for high speed sewing machines and does fine for that purpose.

DB-K5: This needle is virtually the same as 16x257 but has a significant feature designed especially for embroidery machines such as Tajima. The DB-K5 needle has a one size larger eye than that found in a 16x257 needle. For example, a DB-K5 size 10/70 needle has an eye which is at least as large as the eye in a 16x257 size 12/80. Unlike sewing thread used for general apparel sewing, embroidery threads are "fluffier" and have less tensile strength. A larger needle eye, without increased blade diameter, allows the embroidery thread to pass easily through the needle's eye without fraying or snapping.

DBxK5Z1: This is a modified version of the DB-K5 needle. It has a side scarf, long extended groove, longer deeper scarf and slim Xtra Light Ballpoint. The side scarf allows less interference between the needle and the rotary hook. The long extended groove provides more protection to the top thread. The longer deeper scarf allows the hook point to be adjusted closer to the center of the thread loop and allows for variations in registration from one needle position to the next. The slim point reduces penetration resistance

for smoother piercing of the material. This all adds up to smoother, sharper embroidery.

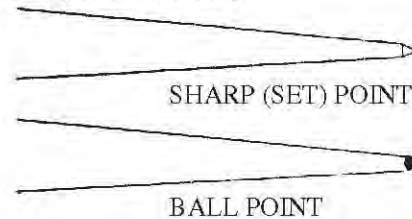

BALL POINT: Ball Point needles are designed to alleviate making holes in knit or loosely woven materials. The cross fibers which constitute the knit or loosely woven materials are relatively far apart as compared to those in tightly woven materials. When a needle with a standard "set" or "sharp" point encounters one of those fibers in penetrating the fabric, it cuts right through the fiber. This creates a hole in the fabric. The Ball Point needle pushes aside the fiber it encounters in penetration and thereby avoids making a damaging hole in the fabric. (It is also recommended to use the thinnest possible needle for a particular fabric).

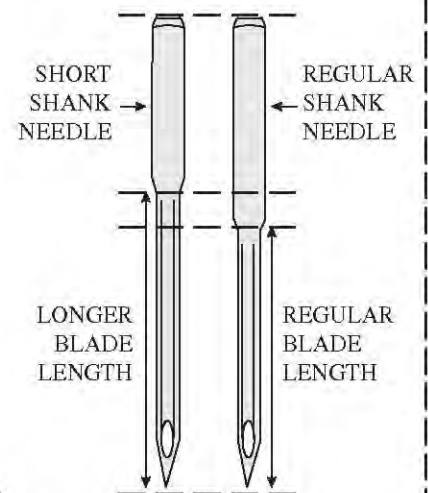
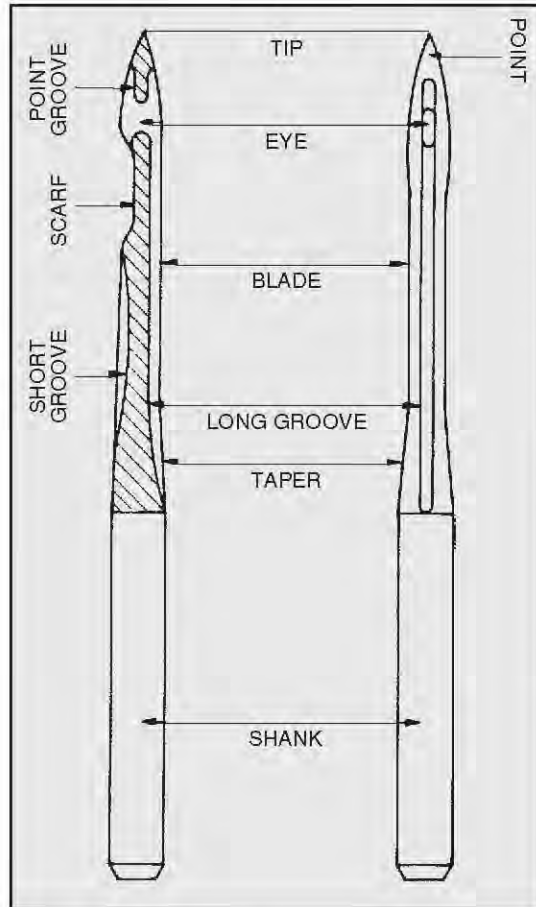

DB-K5kk (Short Shank):

The short shank needles are intended for use in machines with raised needle hole throat plates like in ZSK and Singer KSM models. They are also used to allow more needle penetration in very thick materials thus avoiding "shanking." CAUTION: With a shorter shank length the needle blade has less support and is prone to deflect more than regular needles. When using short shank needles, the use of a thicker size may be required to avoid excessive needle breakage.

DBx9ST: This needle is intended for some extreme situations which have thicker than usual embroidery threads and do not allow you to increase the needle thickness. The eye of a DBx9ST needle is at least two (2) sizes larger than ordinarily found in a given size needle. For instance, a DBx9ST size 9/65 has an eye of at least the size found in a 16x257 size 12/80.

DBx7ST: The eye of the DBx7ST is designed particularly for metallic type embroidery threads. The eye of this needle is shaped like a rectangle. The special eye design facilitates the passage of metallic threads through the needle's eye.

DB-K5SS: The DB-K5SS needle has all the eye features of the DB-K5, but the point has a very narrow wedge to make penetration through leather, vinyl and similar materials easier and neater. A standard "set" or "sharp" point needle punches its way through leather like materials which may make irregularly or undesirably shaped needle holes. The very narrow wedge point "slices" through the leather like materials while making a cleanly cut needle hole.

NEEDLE POINT CUTTING STYLES
in Stitch Hole in Fabric

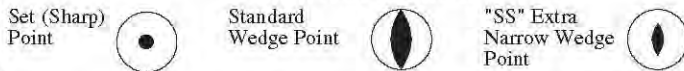

Other available wedge point needles typically have longer wedges than the DB-K5SS needles. That's fine for most sewing operations, but in embroidering, the stitches are very close together. The longer wedge point needles will actually punch out the design created by the close pattern of embroidered stitches. The extra narrow wedge point of the DB-K5SS leaves enough distance between stitches in embroidered patterns to maintain the strength of the leather like material and avoid punching out the embroidered design.

DB-K5SD1: This needle has all of the features of the DB-K5 sharp point needle with the addition of a small triangular tip. This very small triangular tip improves the penetration of hard materials like leather, for smoother stitching.

COOL-SEW: The COOL-SEW finish on needles creates a "non-stick" surface on the needle and inside the needle's eye. It is intended to alleviate many problems that arise from using synthetic threads and synthetic materials. Synthetics usually "stick" to the needle surfaces to some degree, more or less. These problems may also be found with certain chemically treated or dyed fabrics.

As synthetic threads pass through the eye of a needle, they create friction and heat which may melt or snap threads. In some cases, the eye of the needle may be cut. The COOL-

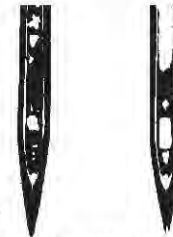

REGULAR NEEDLE

COOL-SEW NEEDLE

Regular needle shows buildup of sticking fibers while Cool-Sew needle is free of buildup.

SEW finished needle eye acts as if eye is lubricated and thereby alleviates the aforementioned problems.

As an ordinary chromium plated needle penetrates through synthetic materials, the materials may stick to the needle. This may cause some of the synthetic materials to pass through the needle holes and create undesirable finishes. The sticking to the surface of the needle may also create heat-buildup problems such as melting and machine jam-ups. The COOL-SEW finish on the needle helps alleviate the sticking and heat-buildup problems.

PD (Perfect Durability): PD needles have a titanium-nitride ceramic finish which makes them more wear-resistant than any other needles. When embroidering large stitch patterns or penetrating very abrasive, dense or tough materials the needle points and surface will maintain its original shape and dimensions 3 to 5 times longer. PD needle points will not wear down as fast as chromium plated needle points. The use of PD needles gives you longer needle life, fewer defects due to "dulled" needle points, and increased productivity.

Test of Wear with the Chrome Plated Needle

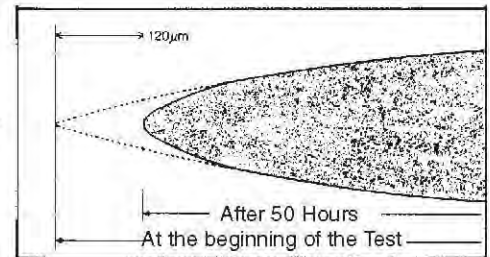

Test of Wear with the PD Needle

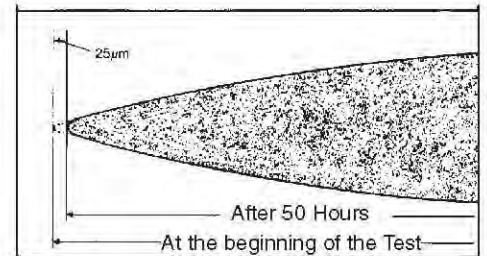

GUIDE TO SELECTING THE RIGHT NEEDLE

ny series: Tapered blade **ny** needles strengthen needles to resist pressure from all directions. A thinner size **ny** needle can perform with the strength of a thicker size needle without excessive needle breakage, fabric damage or needle holes.

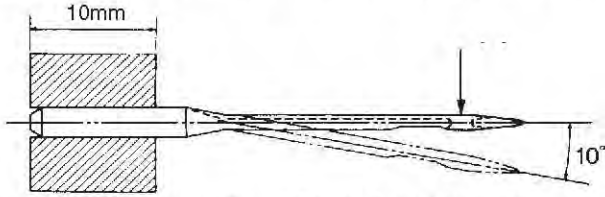

A comparison of strength: ordinary & **ny** needles

287WKH: This was the first needle made specifically for embroidery machines. It is a 16x257 needle with a larger eye and the point shortened so that it will not drag across the previous embroidery when laying down a second or third layer of stitches.

For: FINE KNITS

DBx1KN: This is a modified version of the 16x257 needle specifically for sewing thin knit fabrics. It has a slender, straight blade with a longer, tapered *Thin Ball* point and a revised profile around the eye. The slender, straight blade acts the same as using a one size thinner needle with a consistent slim shape. The longer taper of the needle point reduces the penetration resistance in fabrics to minimize needle holes. The profile around the eye is reduced, to avoid the extra penetration resistance the normal bulge causes.

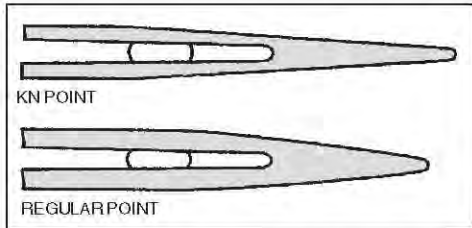

DBxK23: This is the large eye version of the DBx1KN. The area of the eye is increased approximately 25% to accommodate heavier, thicker or "fluffier" threads with less stress in an embroidery application.

DF-M20: This needle has all of the features of the DBx1KN needle with the addition of a flat shank and a longer scarf. It is made specifically for the Tajima Hem-Stitching machine.

For: MEISTERGRAM XL & XLC

(Others use DB-K5)

1906: This is the heavier shank needle with a special scarf for the large bobbin Meistergram machines. It has a standard eye to blade relationship. It is available in regular and ball point, with chrome, Cool-Sew or PD/titanium finishes.

For: FINE KNITS

DPx5KN: This is the heavier shank needle with a slim blade, larger eye and the longer slimmer KN point. It is currently available in size #9/65, with a Ball Point and PD/titanium finish. It works well for sewing lettering or crisp designs on fine knits.

For: CHAINSTITCH & CHENILLE



PH-C70: CEx3; This is the hook needle for chain stitching with a flat spot on the shank, used in the Tajima.



PH-C70SB: CEx1; This is the hook needle with a short barb for chenille with a flat spot on the shank, used in the Tajima.



PH-C120: This is the hook needle for chenille, with a smaller hook opening to avoid snagging on delicate fabrics, with a flat spot on the shank, used in the Tajima.



253: 137x1; This is the screw shank, hook needle for chain stitching, used in Melco, Cornely, Singer 114, Con sew 104 & 133, Treasure, etc.



253SB: This is the screw shank, hook needle with a short barb for chenille, used in Melco, Cornely, Singer 114, Con sew 104 & 133, Treasure, etc.

ORGAN NEEDLES

FOR...

- VALUE
- QUALITY
- DEPENDABILITY



Diamond Needle Corp

60 Commerce Rd. Carlstadt, NJ 07072
 Phone: (201)507-1771 . (800)221-5818
 FAX: (201)507-1715 (800)833-3363 E-mail: info@diamondneedle.com

EW WHITE DIAMOND



FLAT SHANK NEEDLES

15x1: HAx1, 130/705H, SY2020, SY2031, 206x15, PFx130, canu 22:15; This is the standard needle with a flat shank and a regular size eye for most home sewing machines and home sewer based embroidery and quilting machines. It is widely available in a large range of sizes with a sharp or ball point, also available with **PD/titanium** finish.

15x1 SP: HAx1 SP; This is a special version of the 15x1 for **stretch** or **elastic materials** and **tightly woven knits**. It is made to higher standards, it has a snake's head shape due to a combination of a slightly bulged eye and a slightly reduced blade above the eye.



The bulged eye opens a slightly larger space in the material and the thinner blade above the eye reduces contact between the material and the needle. This reduces needle heat-up and prevents skip stitches. It is also available in a light ball point to separate the fibers rather than cutting them, avoiding needle holes in the fabric.

15x1 ST: HAx1 ST, 705H-E; This is a special version of the 15x1 for **embroidery** and **decorative stitching**. It is made to higher standards for longer life. It has an oversized eye to reduce stress and tension on the thread. It also accommodates metallic threads or heavier top stitching threads and makes needle threading easier. It is available in sharp or ball point, also available with **PD/titanium** finish.

HAx130EBBR: This **NEW** needle was developed for use in the new Babylock EMB6 and Brother PR-600C machines. It is an industrial quality needle with a flat shank, reinforced blade, light Ball Point and an oversized eye. It is available with a hard chrome finish.

15x2: HAx2, HAx1LL, 130LR; This is the **leather** point needle with a flat shank. It has all of the same features as 15x1 with the addition of a lens shaped point to cut through leather and other heavy materials. Caution must be used when changing to this needle. Extra space must be left between needle penetrations to avoid 'cutting out' the design.

HLx5: This needle is made for sewing hard, thick or heavy materials. It will sew through multiple ply applications like **quilting, jeans, applique or heavy embroidery**. It is actually an industrial needle with a flat shank. If you are bending or breaking 15x1's this needle could solve your problem. These hard chrome needles will outlast a standard 15x1 and the **PD/titanium** needles are even more wear-resistant. They are available in either sharp or ball point with a hard chrome or **PD/titanium** finish.

Hints & Tips: High quality embroidery is a delicate balance.

Remember when you change:

- Ø The **needle size** or the **eye size** of the needle, you are changing the tension on the top thread.
- Ø The **needle size** you are changing the relationship of the needle scarf to the hook point.
- Ø The **needle point** you are changing the way the needle penetrates the fabric.

This is not just about needles! When you change thread, backing, brand of blank product or even digitizers you may also affect the balance.

**NEED SOMETHING NOT SHOWN?
CALL AND ASK-
WE STOCKS 1000's OF
ITEMS FOR
IMMEDIATE DELIVERY**

© Copyright 2004 by Diamond Needle Corp.





ORGAN NEEDLES



Created with precision to serve all sewing demands

NEEDLES FOR ALL MULTI-HEAD EMBROIDERY MACHINES

For machines by: TAJIMA, BARUDAN, TOYOTA, MELCO, HAPPY, MEISTERGRAM, ULTRAMATIC, PFAFF, BROTHER, ZSK, ZANGS, SWF, RENAISSANCE, MARCO, GROSS, AND ALL OTHERS...

NEEDLE TYPE	DESCRIPTION	AVAILABLE SIZES
LARGE EYE		
DB-K5	Regular Point	8/60, 9/65, 10/70, 11/75, 12/80, 14/90, 16/100, 18/110
DB-K5 BP	Ball Point	8/60, 9/65, 10/70, 11/75, 12/80, 14/90, 16/100, 18/110
DB-K5 U	Heavy Ball Point	11/75
DB-K5 CS	Reg. Point, Non-Stick	8/60, 9/65, 10/70, 11/75, 12/80, 14/90, 16/100, 18/110
DB-K5 BP CS	Ball Point, Non-Stick	8/60, 9/65, 10/70, 11/75, 12/80, 14/90, 16/100
DB-K5 PD	Reg. Point, Titanium	8/60, 9/65, 10/70, 11/75, 12/80, 14/90, 16/100, 18/110
DB-K5 BP PD	Ball Point, Titanium	8/60, 9/65, 10/70, 11/75, 12/80, 14/90, 16/100, 18/110
DB-K5 NY	Reg. Point, Tapered	8/60, 9/65, 10/70, 11/75, 12/80, 14/90
DB-K5 BP NY	Ball Point, Tapered	8/60, 9/65, 10/70, 11/75, 12/80, 14/90
LEATHER POINT		
DB-K5 SS	Extra Narrow Wedge	11/75, 12/80, 14/90, 16/100, 18/110
DB-K5 SD1 PD	Round Tri-Tip, Titanium	10/70, 11/75, 12/80, 14/90, 16/100, 18/110
SHORT SHANK		
DB-K5 KK	Regular Point	9/65, 10/70, 11/75, 12/80, 14/90
DB-K5 KK BP	Ball Point	9/65, 10/70, 11/75, 12/80
METALLIC EYE		
DBx7ST	Regular Point	11/75, 12/80, 14/90, 16/100
DBx7ST BP	Ball Point	11/75, 12/80, 14/90, 16/100
EXTRA LARGE EYE		
DBx9ST	Ball Point	9/65, 11/75, 14/90
REGULAR EYE		
16x257	Regular Point	8/60, 9/65, 10/70, 11/75, 12/80, 14/90, 16/100, 18/110
16x257 BP	Ball Point	8/60, 9/65, 10/70, 11/75, 12/80, 14/90, 16/100, 18/110
16x257 CS	Reg. Point, Non-Stick	10/70, 11/75, 12/80, 14/90, 16/100, 18/110
16x257 BP CS	Ball Point, Non-Stick	10/70, 11/75, 12/80, 14/90, 16/100, 18/110
16x257 PD	Reg. Point, Titanium	8/60, 9/65, 10/70, 11/75, 12/80, 14/90, 16/100, 18/110
16x257 BP PD	Ball Point, Titanium	8/60, 9/65, 10/70, 11/75, 12/80, 14/90, 16/100, 18/110
16x257 NY	Reg. Point, Tapered	9/65, 10/70, 11/75, 12/80, 14/90
16x257 NY BP	Ball Point, Tapered	9/65, 10/70, 11/75, 12/80, 14/90
16x257	Leather Point	Use: DB-K5 SS or DB-K5 SD1 PD
SHORT POINT		
287WKH	Regular Point	8/60, 9/65, 10/70, 11/75, 12/80, 14/90, 16/100, 18/110
287WKH BP	Ball Point	8/60, 9/65, 10/70, 11/75, 12/80, 14/90, 16/100, 18/110
287WKH CS	Reg. Point, Non-Stick	10/70, 11/75, 12/80, 14/90, 16/100, 18/110
287WKH BP CS	Ball Point, Non-Stick	10/70, 11/75, 12/80, 14/90, 16/100
287WKH PD	Reg. Point, Titanium	9/65, 10/70, 11/75, 12/80, 14/90
287WKH BP PD	Ball Point, Titanium	9/65, 10/70, 11/75, 12/80, 14/90

We also carry all other types and sizes of Sewing Machine Needles

Diamond Needle Corp.

60 Commerce Rd. - Carlstadt, NJ 07072
tel: (201) 507-1717 - 800-221-5818
fax: (201) 507-1715 - 800-833-3363
email: info@DiamondNeedle.com



November 1, 2010



ORGAN NEEDLES



Created with precision to serve all sewing demands

NEEDLES FOR ALL MULTI-HEAD EMBROIDERY MACHINES

For machines by: TAJIMA, BARUDAN, TOYOTA, MELCO, HAPPY, MEISTERGRAM, ULTRAMATIC, PFAFF, BROTHER, ZSK, ZANGS, SWF, RENAISSANCE, MARCO, GROSS, AND ALL OTHERS...

NEEDLE TYPE	DESCRIPTION	AVAILABLE SIZES	USED FOR
DBx1KN	Slim Ball Point	9/65, 10/70, 11/75, 12/80, 14/90	Fine Knits
DBx1KN BP	Slim Ball Point	9/65, 10/70, 11/75, 12/80, 14/90	Fine Knits
DBxK5Q1	Light Ball Point	8/60, 9/65, 10/70, 11/75, 12/80	MB4, EP4
DBxK5Q1-NY	Light Ball Point	8/60, 9/65, 10/70, 11/75, 12/80	MB4, EP4
DBxK5Z1	Light Ball Point	10/70, 11/75, 12/80, 14/90	Foam
DBxK5Z1 PD	Light Ball Point, Titanium	10/70, 11/75, 12/80, 14/90	Foam
DBxK23	Regular Point, Knit	9/65, 10/70, 11/75, 12/80	Fine Knits
DBxK23 BP	Ball Point, Knit	9/65, 10/70, 11/75, 12/80	Fine Knits
DBxK23 PD	Reg. Point, Knit, Titanium	9/65, 10/70, 11/75, 12/80	Fine Knits
DF-M20	Hem Stitch	10/70, 11/75, 12/80, 14/90	Hem Stitch
Hook Needles For: Tajima Chainstitch			
PH-C70	Chainstitch	11/75, 14/90, 16/100, 18/110, 19/120, 21/130	Chainstitch
PH-C70SB	Chenille (Short Barb)	16/100, 18/110, 19/120	Chenille
PH-C120	Smaller Hook Opening	11/75, 14/90, 16/100	Fine Chenille
PHx7BA (5935-40)	Singer Style	19/120	Combination
Hook Needles For: Melco, Cornely, Singer 114, Consew 104 & 133, Treasure, etc.			
253 (137x1, PHx1)	Chainstitch	2/12/80, 3/14/90, 4/16/100, 5/18/110, 6/19/120, 7/21/130	Chainstitch
253SB (137x3, PHx1SM)	Chenille (Short Barb)	4/16/100, 5/18/110, 6/19/120	Chenille
For: Original Meistergram XL & XLC			
1906	Regular Point	8/60, 9/65, 10/70, 11/75, 12/80, 14/90, 16/100, 18/110	Heavy Shank
1906 BP	Ball Point	8/60, 9/65, 10/70, 11/75, 12/80, 14/90, 16/100, 18/110	Heavy Shank
1906CS	Reg. Point, Cool Sew	10/70, 11/75, 12/80	Heavy Shank
1906 BP CS	Ball Point, Cool Sew	10/70, 11/75, 12/80	Heavy Shank
1906 PD	Reg. Point, Titanium	11/75	Heavy Shank
1906 BP PD	Ball Point, Titanium	11/75	Heavy Shank
DPx5KN PD	Knit Point, Titanium	9/65	Heavy Shank

No. NDLKIT-1 (ROUND SHANK)

ORGAN NEEDLE SAMPLER NEEDLE ASSORTMENT

When a problem job appears, you can have the correct needle for that project. The kit contains 19 packs (10 needles per pack) with an extensive assortment of needles. The needles are packed in a compact plastic storage box with important information about the different needles.

Listed below are the needles packed in our special assortment kit (10 of each needle):

- DB-K5 Regular Point: #8/60, #9/65, #10/70, #11/75, #12/80, #14/90
- DB-K5 Ball Point: #8/60BP, #9/65BP, #10/70BP, #11/75BP, #12/80BP
- DBx7ST #11/75 Regular Point & #11/75 Ballpoint Metallic Thread Eye
- DBx9ST #11/75 Ballpoint Double Large Eye
- DB-K5SS #11 Leather Point
- DB-K5 #11CS Regular Point & #11BPCS Ballpoint *Cool-Sew*
- DB-K5 #11PD Regular Point & #11BPPD Ballpoint *Perfect Durability*



Diamond Needle Corp.

60 Commerce Rd. - Carlstadt, NJ 07072
tel: (201) 507-1717 - 800-221-5818
fax: (201) 507-1715 - 800-833-3363
email: info@DiamondNeedle.com



**WHITE
DIAMOND**

November 1, 2010

THREADING HOOKS & HOLDER

Simplifies and Speeds Needle Threading



- #A1 THREADING HOOKS (25 per pack)
- #SHT1 THREADING HOOK HOLDER (4-1/2")
- #SHT2 THREADING HOOK HOLDER (7-3/4")
- #EW401 THREADING WIRE (7-3/4") For Chainstitch Machines

ORGAN NEEDLES

FOR SCHIFFLI MACHINES...

GUARANTEED QUALITY • ECONOMICAL PRICES • FAST DELIVERY

NEEDLE TYPE	DESCRIPTION	AVAILABLE SIZES
For: PLAUEN, REINER, ZANGS, Etc.		
854S	REGULAR POINT	0, 1, 2, 3, 4, 5, 7 (also #0 with #1 eye)
854S BP	BALL POINT	0, 1, 2 (also #0 with #1 eye)
854S CS	REGULAR POINT, NON-STICK	1, 2
854S NOTCHED	REGULAR POINT, NOTCHED	1, 2
854S BP NOTCHED	BALL POINT, NOTCHED	1, 2
Color Change		
0854	REGULAR POINT	0, 1, 2
0854	BALL POINT	0, 1
For: SAURER		
110S	REGULAR POINT	0, 1, 2, 3, 4, 5, 7 (also #0 with #1 eye)
110S BP	BALL POINT	0, 1, 2 (also #0 with #1 eye)
110S CS	REGULAR POINT, NON-STICK	1
110S NOTCHED	REGULAR POINT, NOTCHED	1 (also #0 with #1 eye)
110S BP NOTCHED	BALL POINT, NOTCHED	1, 2
110S-TOP	REGULAR POINT	1, 2, 3
110S-TOP BP	BALL POINT	1
Color Change		
0110	REGULAR POINT	0, 1, 2, 3
0110 BP	BALL POINT	0, 1, 2
For: FRAME		
445S	REGULAR POINT	1, 2, 3
445SK	REGULAR POINT	1, 2, 3

FOR MERROW MACHINES

MERROW	REGULAR POINT	00D, 0D, 1D, 2D, 3D, 4D, 5D, 6D, 7D, 8D
MERROW BP	BALL POINT	00D, 0D, 1D, 2D, 3D, 4D
MERROW CS	REGULAR POINT, NON-STICK	2D

Diamond Needle Corp

60 Commerce Rd. Carlstadt, NJ 07072
 Phone: (201)507-1771 . (800)221-5818
 FAX: (201)507-1715 (800)833-3363 E-mail: info@diamondneedle.com





ORGAN NEEDLES



Created with precision to serve all sewing demands

These needles have a flat side ground on the shank to assure proper alignment with the point of the hook. (Intended only for machines designed for Flat Shank needles).

FLAT SHANK NEEDLES

For machines by: Bernina, Brother, Elna, Husqvarna, Janome, Juki, Melco, Necchi, Baby Lock, New Home, Pfaff, Riccar, Simplicity, Singer, Viking, White & more...

NEEDLE TYPE	DESCRIPTION	AVAILABLE SIZES	PRICE PER HUNDRED	USED FOR
15x1, HAx1, 130/705H	Regular Point	9/65, 10/70, 11/75, 12/80, 14/90, 16/100, 18/110, 20/125		Standard
15x1, HAx1 BP	Ball Point	9/65, 10/70, 11/75, 12/80, 14/90, 16/100, 18/110		Standard
15x1, HAx1 PD	Regular Point, Titanium	9/65, 10/70, 11/75, 12/80, 14/90, 16/100, 18/110		Standard
15x1, HAx1 BP PD	Ball Point, Titanium	9/65, 10/70, 11/75, 12/80, 14/90, 16/100, 18/110		Standard
15x1SP	Regular Point, Elastic	11/75, 14/90		Elastic
15x1SP BP	Ball Point, Elastic	11/75, 14/90		Elastic
15x1ST, 130/705H-E	Regular Point, Large Eye	11/75, 12/80, 14/90		Embroidery
15x1ST BP	Ball Point, Large Eye	11/75, 12/80, 14/90		Embroidery
15x1ST PD	Reg. Pt., Lg. Eye, Titanium	11/75, 12/80, 14/90		Embroidery
15x1ST BP PD	Ball Pt., Lg. Eye, Titanium	11/75, 12/80, 14/90		Embroidery
15X2, 130/705H LL	Leather Point	11/75, 14/90, 16/100, 18/110		Leather
ELx705	Light Ball Point	11/75, 12/80, 14/90		Chain Stitch
HAx1KN	Slim, Ball Point	11/75, 14/90		Fine Knits
HAx130EBBR	Light Ball Point	9/65, 10/70, 11/75, 12/80, 14/90		PR-600, EMB6
HAx130N	Regular Point	12/80, 14/90, 16/100		Top Stitch
HAx130N PD	Regular Point, Titanium	12/80, 14/90, 16/100		Top Stitch
HAx130SPI	Slim, Sharp Point	8/60, 9/65, 10/70, 11/75, 12/80, 14/90		Micro-Fiber
HLx5	Regular Point	9/65, 10/70, 11/75, 12/80, 14/90, 16/100, 18/110		Quilting
HLx5 BP	Ball Point	9/65, 10/70, 11/75, 12/80, 14/90, 16/100, 18/110		Quilting
HLx5 PD	Regular Point, Titanium	9/65, 10/70, 11/75, 12/80, 14/90, 16/100, 18/110		Quilting
HLx5 BP PD	Ball Point, Titanium	9/65, 10/70, 11/75, 12/80, 14/90, 16/100, 18/110		Quilting

No. NDLKIT-FL-A (FLAT SHANK)

ORGAN NEEDLE SAMPLER NEEDLE ASSORTMENT

Contains a solution for most embroidery problems!

When a problem job appears, you can have the correct needle on hand. This kit contains 20 packs (10 needles per pack) of different needles. The extensive assortment comes in a compact plastic storage box with important information about the different needles.

Each kit contains:

- 15x1 Regular Point #9/65, 10/70, 11/75, 12/80, 14/90, 16/100, 18/110;
- 15x1 Ball Point: #9/65, 10/70, 11/75, 12/80, 14/90, 16/100;
- 15x1 PD, Regular Point Perfect Durability #11/75;
- 15x1 BP PD, Ball Point Perfect Durability #11/75;
- 15x1 ST, Large Eye Regular Point #11/75, 14/90;
- 15x1 ST BP, Large Eye Ball Point #11/75;
- 15x1 SP, Elastic Regular Point #11/75, 14/90.



Diamond Needle Corp.

60 Commerce Rd. - Carlstadt, NJ 07072
 tel: (201) 507-1717 - 800-221-5818
 fax: (201) 507-1715 - 800-833-3363
 email: info@DiamondNeedle.com



November 1, 2010

ORGAN NEEDLES

Created with precision to solve any sewing problem



SINGER

7x1 #18-27
7x1 #28-30
7x2DP
7x3 #18-27
7x3 #28-30
7x4DP
7x4NW
7x23 #21-27
7x23 #28
15x1
15x1SP
15x1ST
15x2
16x1
16x2DP
16x2NW
16x2RTW
16x2TRI
16x6
16xS45
16x63
16x71
16x75
16x87
16x95
16x99
16x231
16x231-NY2 PD
16x231-NY2-SD1 PD
16x246
16x248
16x257
16x257-NY2 PD
16x257-NY2-SD1 PD
16x257LR
24x1
29x3
29x4
31x1
46x2TRI
52x1
52x5
52x7
55x3
62xs14DP
62x40SP
62x43
62x45
62x57
62x59
62x59SD1
62x59SD1 PD
68x3
68x5
71x1
75x1
81x1
81X5
82x13
88x1

88x5
88x9
92x1 #22-25
92x1 #26-27
97x3
108x1
108x3
124x2
126x3
126x9
126x11
126x11SERV1
128x1
128x2
128x3
128x4
128x6
128x20
128x21
128x22
129x1
130x3
134x1
135x1
135x5
135x5-NY2 PD
135x5-NY2-SD1 PD
135x6
135x7
135x7-NY2 PD
135x7-NY2-SD1 PD
135x8DP
135x8NW
135x8RTW
135x8TRI
135x9
135x11
135x16DP
135x16NW
135x16RTW
135x16TRI
135x17
135x17-NY2 PD
135x17-NY2-SD1 PD
135x17-SERV2
135x53
135x65
137x1
141x1
142x5
149x1
149x3
149x5
149x7
149x25
151x1
151x7
151x21
151x23
175x1
175x3
175x5
175x7

175x9
175x13
214x1
214x2RTW
216x1
216x7
1431
1433
1435
1437
1906
1907
1955
1963
1965
JET#20

AMER. EDGE BASTER

75W

BAGS, DOBOY, FISCHBEIN

BSx723
C100S
D5F
D5R
DRx600
DR-H30
748-00027A

BLINDSTITCH

251
251EL
251EU
251LG
1715E
29-6/29BB
29-12/29BC
29-13/29BD
29-34/29BL
29-39/29BK
29-49/29BL

CARPET MACHINERY

123-14LGPT PD
1970A
K60 #23
SG-N28
Titan7713
Titan7713 PD

CHANDLER

146
471
135x1FS
175x1FS

DURKOPP-ADLER, PFAFF, etc.

34D

34DI
34LL
34LR
34P
34PCL
34PCR
34R
34S
81LR
88R
88HK
130B
130LR
130R
133R
134D
134Di
134K
134KK
134KKPCL
134KKPCL
134LR
134PCL
134PCR
134R
134R-NY2 PD
134R-NY2-SD1 PD
134S
134-35D
134-35DI
134-35K
134-35LR
134-35R
134-35R-NY2 PD
134-35R-NY2-SD1 PD
175H
190D
190LR
190R
265-5
265-50
328LR
328R
332LG
332LR
332R
438R
556KH
558
794
794Di
794S
797
797D
797Di
797KH
797LR
797S
805LR
933
934
971B
1000

Diamond Needle Corp

60 Commerce Rd. Carlstadt, NJ 07072
Phone: (201)507-1771 . (800)221-5818
FAX: (201)507-1715 (800)833-3363 E-mail: info@diamondneedle.com

WHITE
DIAMOND

ORGAN NEEDLES

Created with precision to solve any sewing problem



MY1014
1738(A)
1807(D)
1886
1886KK
2134-35D
2134-35Di
2134-35K
2134-35LR
2134-35R
3207

FLAT SHANK

130LR
130R
130R BP
705H
705H BP
705LR
DN2

HOSIERY

4117
4118
154GDS
8454G
MERROW #B-2SD

JAPANESE SYSTEMS

BLx1
BLx2N
Dax1
DBx1
DB-G52
DCx1
DCx1F
DCx3
DCx27
DCxN17
DMx13
DNx1 #22-25
DNx1 #26-27
DUx1
DV-K25
DVx210
DVx600
EBx1
EBx2
JLx1
JLx2
PFx797
SLx75
Tex1
TQx1
TQx7
TVx64

JUKI

DCx27
Dix3
DPx58
TVx5

TVx64

KANSAI

62x40SP
DV-K25
DVx210
DVx600
UOx113

LEWIS BUTTONSEWER

29S
29LS
29LSS

MERROW

60MSD
#0D-8D
#2SD
A-2SD
B-1SD
B-2SD
MERROW
Straight #8
Straight #10H
MRx59#24

PORTABLE SERGERS

SY2053
SY2054
SY2922
BLx1
BLx2N
BLx4
DCx1F
ELx705
JLx1
JLx2
SLx75
TEx1

QUILTING

7x3KF
7x3KF PD
7x3KFL
7x3KFR
7x3KSPFL
7x3KSPFL PD
7x3KSPFR
7x4KF
88R
88HK
175H
328FL-E
490
490F
794HFL
794HFR
794HMR
794HMR-3
794HMR-4 PD
794HMR-4-SD1PD

860(D)
862(D)
882XL
2044FL-E
2331
2331F
2331FLG
2331FEXT,LG
2345FR-SPI
2390
48:50
48:51
DD-E39
EBx1
EBx2
EBx3
SY8145-01
SY8167-02

REECE

501SC
750SC
751SC
752SC
950SC
951SC

RIMOLDI

B26
B27
B27-SD1 PD
B27FM-B
B29
B63
B64
B67
1886

SADDLE STITCH

29C150
29C151
29DEA
29DHD
CPx1
CPx12
CPx13
CPx17
CPx170
CPx200
CPx600

UNION SPECIA

101G
106G
108G
110G
113G
118GAS
118GBS
118GHS
118GKS
120G
121G

121GUS
126G
128G
128G-NY2-PD
130G
133G
143G #054-080
143G #090-100
147G
150G
154FGS
154GAS
154GBS
154GCS
154GDS
154GFS
154GHS
155G
158G
162GBS
162SAS
163SAS
180G
183G
192G
943G #067-080
943G #090-100
947G
1970G
1975G
8454G
8456G
9848G
9854G
9858G

**NO ADDITIONAL CHARGE
FOR BALL POINT**

**ADDITIONAL CHARGES:
COOL-SEW 42.00**

**CONTACT US FOR
NEEDLES NOT LISTED**

**PRICES QUOTED in U.S.
DOLLARS
per 1,000 pcs.**



EFFECTIVE March 1, 2004

Diamond Needle Corp

60 Commerce Rd. Carlstadt, NJ 07072
Phone: (201)507-1771 . (800)221-5818
FAX:(201)507-1715 (800)833-3363 E-mail:info@diamondneedle.com

EW WHITE
DIAMOND

MARCH 1, 2004

PRICES SUBJECT TO CHANGE WITHOUT NOTICE. NOT RESPONSIBLE FOR TYPOGRAPHICAL ERRORS.

11

ORGAN NEEDLES

Created with precision to solve any sewing problem



<p>PERFECT DURABILITY</p> <p>7x3 PD 16x95 PD 16x231 PD 16x231-NY2 PD 16x231-NY2-SD1 PD 16x257 PD 16x257-NY2 PD 16x257-NY2-SD1 PD 62x43 PD 62x45 PD 62x57 PD 62x59 PD 62x59SD1 PD 71x1 PD 81x1 PD 135x5 PD 135x5-NY2 PD 135x5-NY2-SD1 PD 135x5CL PD 135x5CR PD 135x7 PD 135x7-NY2 PD 135x7-NY2-SD1 PD 135x17 PD</p>	<p>135x17-NY2 PD 135x17-NY2-SD1 PD 135x53 PD 135x65 PD 135x8 PD 135x16DP PD 135x16TRI PD 142x5 PD 149x3 PD 149x5 PD 149x7 PD 175x7 PD 1906 PD 1955 PD</p> <p>PD for Durkopp-Adler, Pfaff, etc</p> <p>134R PD 134-35R PD 134-35DIA PD 134-35D PD 134-35R-NY2 PD 134-35R-NY2-SD1 PD 134R-NY2 PD 134R-NY2-SD1 PD 2134-35R PD</p>	<p>PD for QUILTING</p> <p>7x3KF PD 7x3KSPFL PD 794HMR-4 PD 794HMR-4-SD1 PD</p> <p>PD for REECE</p> <p>501SC PD 750SC PD</p> <p>PD for RIMOLDI</p> <p>B27 PD B27-SD1 PD B64 PD B63 PD</p> <p>PD for UNION SPECIAL</p> <p>113G PD 118GBS PD 128G PD 128GAS-NY2 PD 128GBS-NY2 PD 128GBS PD 130G PD</p>	<p>PD for EMBROIDERY</p> <p>DB-K5 PD DB-K5SD1 PD DB-K5Z1 PD DB-K23 PD 287WKH PD</p> <p>PD MISCELLANEOUS</p> <p>DCx27 PD DV-K25 PD 123-14LGPT PD DYx3 PD TTx7713 PD</p> <p>PD for FLAT SHANK</p> <p>HLx5 PD 15x1 PD 15x1ST PD 705H-E PD 130R PD</p>
---	--	---	---



PD Perfect Durability Needles:

Organ Needle Company has managed to combine the functionality of sewing machine needles with the latest technology of ceramic coatings. These new **PD (Perfect Durability)** needles have titanium nitride layered on their surfaces to extend their productive life by as much as five times that of conventional needles.

Lasts Five Times Longer Than Chrome-Plated Needles

Productivity of automated embroidery equipment is limited by the life of their needles. **PD** titanium coated needles are significantly stronger than other needles while maintaining elasticity. This reduces needle breakage, bending and distortion. **PD** needles are more wear resistant than conventional chromium plated needles. **PD** needles provide *perfect* reliability and *durability* in prolonged stitching operations.

Stronger at the Point of the Needle

Organ's process for making **PD** needles also strengthens the point of the needle. The point of a needle is exposed to high pressures causing needle wear and breakage. The strength of the needle has been reinforced while maintaining a perfect shape in order to provide greater wear resistance and durability.

Test of Wear with a Chrome Plated Needle

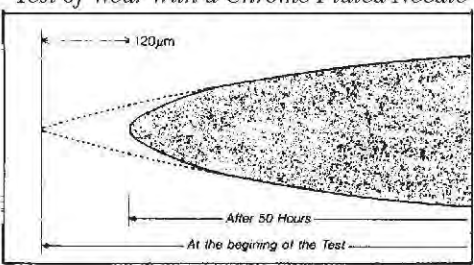

Test of Wear with the PD Needle

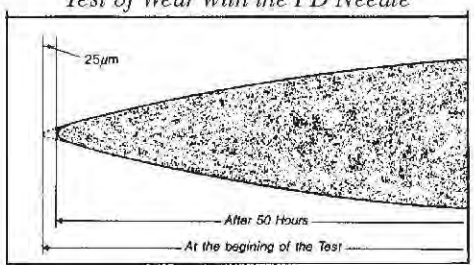

Using **PD** needles means better quality stitches, less downtime, higher productivity and *lower cost* production.

Diamond Needle Corp

60 Commerce Rd. Carlstadt, NJ 07072
Phone: (201)507-1771 . (800)221-5818
FAX: (201)507-1715 (800)833-3363 E-mail: info@diamondneedle.com





WHITE
DIAMOND

PUNCH PINS (Boring Needles)

Design Cutouts Like Lace or Sewn Eyelets on Standard Embroidery Machines

Create beautiful, cutout patterns surrounded by embroidery without awkward and expensive boring attachments.

Our **#EWPP23 Punch Pins (boring needles)** let you use your standard embroidery machines to produce all shapes of cutout designs combined with your embroidered patterns. No need for special offset boring attachments which are not only awkward, but very expensive, too.

The **Punch Pin** is normally installed in the first or last needle bar (*so you can remember where it is*). An outline is sewn around the area to be punched out to stabilize the material and backing. Program the **Punch Pin** to fill in the outlined area. The designated area is then punched out, followed by the sewing of the rest of the embroidery pattern. You can even make eyelets in finished hats.

Specially shaped, sharpened, and hardened points allow for accurate, clean cuts repeatedly.

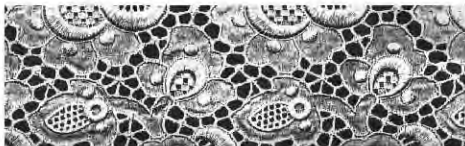
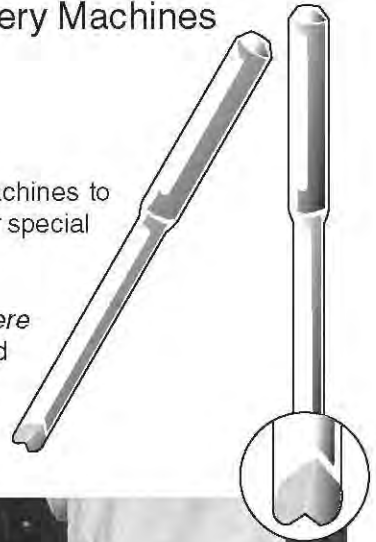

#EWPP23/2 (2/pack)

#EWPP23/10 (10/pack)

Can be used in ANY standard Multi-Needle embroidery machine !

CS Cool-Sew Needles:

Less Thread Breakage, Less Sticking, Less Downtime

The **Cool-Sew** finish on the needle surfaces and in the needle's eye is resistant to sticking. Its finish has a very low friction coefficient, which prevents excessive heat buildup and resulting problems. Few, if any, materials stick to the surfaces of **Cool-Sew** needles.

Cool-Sew needles are ideal for stitching through vinyl, synthetics, chemically treated materials, glued materials, rubberized goods, nylon, foam, dense materials, and with synthetic threads.

When **Cool-Sew** needles are used under conditions described above you can expect neater stitches, less sewing thread breakage, less puckered stitches, less downtime, less defects, and increased productivity.

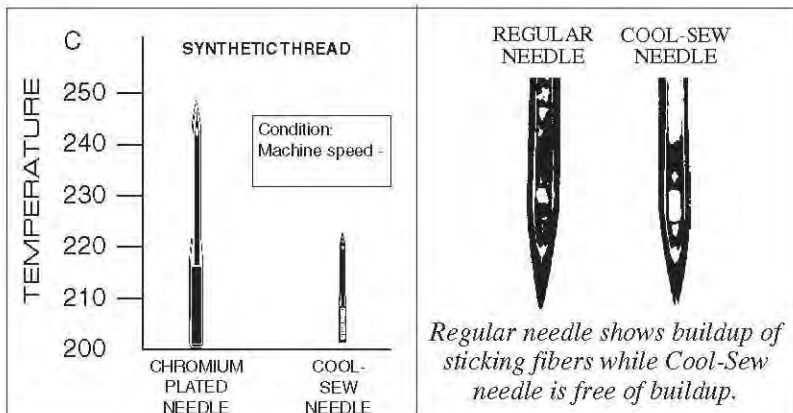

Diamond Needle Corp

60 Commerce Rd. Carlstadt, NJ 07072
Phone: (201)507-1771 . (800)221-5818
FAX: (201)507-1715 (800)833-3363 E-mail: info@diamondneedle.com



MARCH 1, 2004

PRICES SUBJECT TO CHANGE WITHOUT NOTICE. NOT RESPONSIBLE FOR TYPOGRAPHICAL ERRORS.

ny SERIES

Tapered blade **NY** needles strengthen needles to resist pressure from all directions. A thinner size **NY** needle can perform with the strength of a thicker size needle without excessive needle breakage, fabric damage or needle holes.

Thinner Needle... More Resilient Strength

The redesigned, tapered blade **NY** needles help strengthen needles to resist pressure from all directions. With **NY** needles a thinner size needle can perform with the strength of a thicker one without extra needle breakage. A thinner **NY** tapered blade needle will reduce fabric damage and needle holes. You will find that a thinner size **NY** needle will have the strength of a one size thicker needle and the benefits of its thinner size without excessive needle breakage.

- A comparison of needle shapes

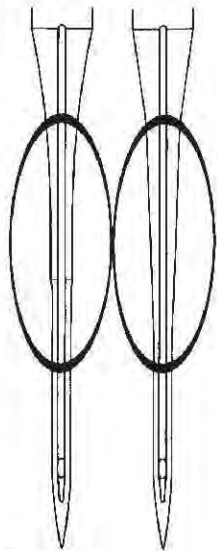

Ordinary needle NY-needle

- A comparison of strength: an ordinary needle vs the **NY**-needle

Strength measure test (by Organ Needle test)

Left graphs show the results on measurements bending the needle at the center of the needle-eye by 10 degrees, holding the shank for 10mm and keeping the long groove to the outside radius

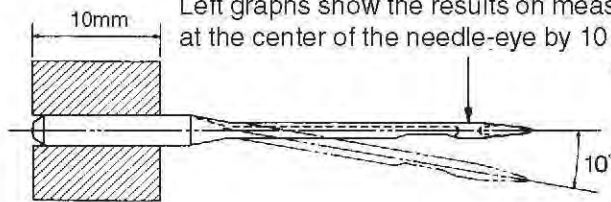

g (Using ordinary DB x 1 and compared with other Organ needle)

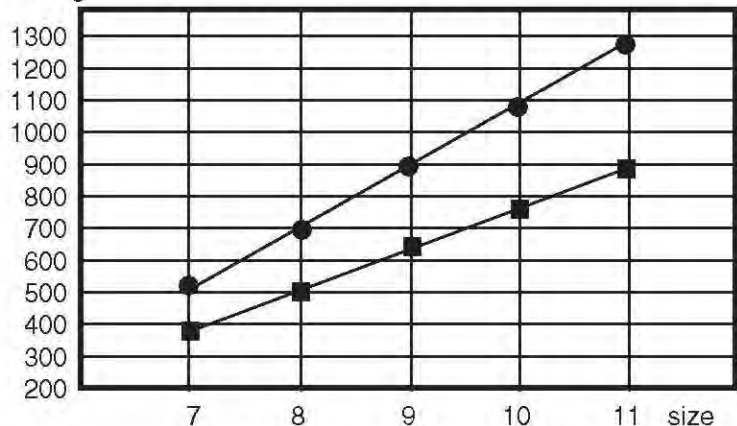

● NY-needle
■ Ordinary needle

SEMI-AUTOMATIC BOBBIN WINDER

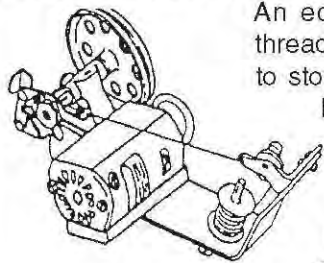

An economical device to wind thread on metal bobbins. No need to stop a job to wind a matching bobbin of thread.

Wind as many or as few as you want. Small, portable size fits on any table. (Equipped with detachable foot control). *Easy to use!*

#BW110 110v Semi-automatic Bobbin Winder

#BW220 220v Semi-automatic Bobbin Winder

BOBBINS

We stock many types of steel and aluminum bobbins

for embroidery and sewing machines.
**REGULAR (L) • LARGE (M)
SPECIALS**



Please use machine builders' reference numbers and/or machine make & model.

Save when you buy them by the hundred!

Diamond Needle Corp

60 Commerce Rd. Carlstadt, NJ 07072
Phone: (201)507-1771 . (800)221-5818
FAX: (201)507-1715 (800)833-3363 E-mail: info@diamondneedle.com

